

# MS985

Mariner Kit for use with the HP LP2065  
20-inch TFT monitor (Wall mount)



The HP LP2065 20-inch TFT monitor is type-approved by all of the major international marine Classification Societies when it is installed in conjunction with our Mariner Kit MS985.

The MS985 Mariner Kit is designed to fit onto any vertical surface and affords protection against the effects of vibration and shock experienced in the offshore marine environment. The combination has been type-tested against IACS Unified Requirement E10 and the relevant sections of IEC60945 (see bottom right for test details).

This type-approved combination of hardware and Mariner Kit can be used as the platform for your critical navigation, control, loading and general purpose applications (please check individual type-approval certificates for any restrictions).

Please note that although the monitor does retain its standard functionality we do not offer an automatic dimming function and it can not therefore be used in the front of the bridge where it may affect night vision. However, the TFT monitor can be used in any area where night vision is not an issue, e.g. 'behind the curtain'.

**“Steer the right course  
with Mariner Systems”**



## WHAT IS SO SPECIAL ABOUT THE HP LP2065 20-INCH TFT MONITOR?

- ◆ Native 1600 x 1200 resolution with over 16 million colours
- ◆ Two DVI-I connectors (VGA analog and digital)
- ◆ The on-screen display button controls on the monitor front allows quick and easy adjustment of brightness, contrast and numerous other settings
- ◆ Reduced eyestrain and fatigue with anti-static and anti-glare film coatings
- ◆ New HP Display LiteSaver feature gives the user the ability to power up and power down the monitor at predetermined hours of the day to save power and backlight life
- ◆ Environmentally sound design uses recyclable plastics for low emissions (TCO 03)
- ◆ Global product availability
- ◆ Three-year limited parts and repair labour on-site warranty

This Mariner system is type-tested against the consolidated, 'worst-case' requirements of all the major international marine Classification Societies:

**ABS, BV, CCS, DNV, GL, KR, LR, NKK, PRS, RINA**

Type-tests included on the test programme are as follows:

- > Vibration, Shock, Static and Dynamic Inclination
- > Dry & Damp Heat, Low Temperature
- > Acoustic Noise, Compass Safe Distance
- > High Voltage, Power Supply Variation & Power Supply Failure
- > Conducted LF & RF, Electromagnetic Field
- > Radiated & Conducted Emissions, Electrostatic Discharge
- > Insulation Resistance, Burst / Fast Transients
- > Surge Immunity, Access to Dangerous Voltages

# MS985

## Mariner Kit for use with the HP LP2065 20-inch TFT monitor (Wall mount)

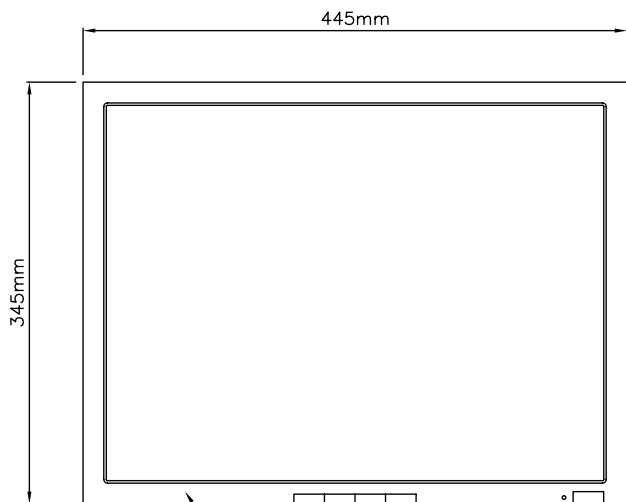

HP LP2065 20" TFT Monitor

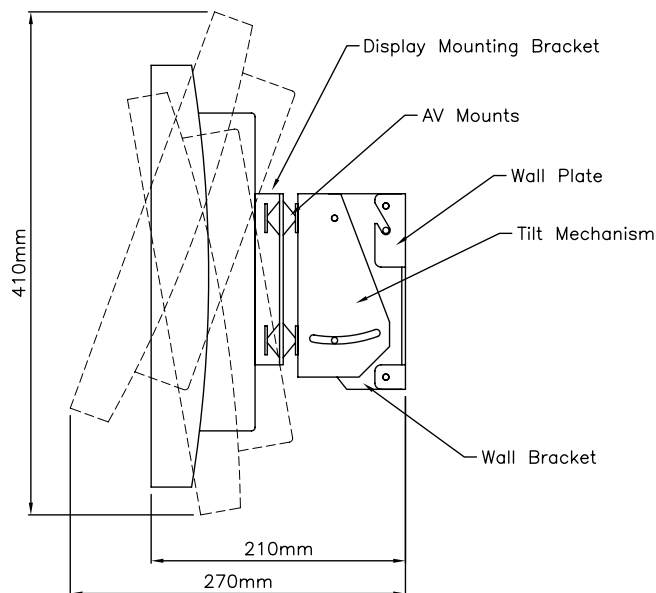

### Mariner Systems (UK) Limited

Oaklands Park • Wokingham • Berkshire • RG41 2FD • United Kingdom  
Telephone: +44 (0) 118 979 6020 • Facsimile: +44 (0) 118 979 6021  
sales@marinersystems.com • www.marinersystems.com

## OPERATING GUIDELINES

Although all our equipment is tested against extreme environmental conditions for the purposes of marine type-approval, installation should take into account the following guidelines:

- > Keep the monitor away from excessive moisture, direct moisture and the extremes of heat and cold, to ensure that the unit is within the manufacturer's specified operating/non-operating ranges:

	Operating	Non-Operating
<b>Temperature</b>	+5° to +35°C (+41° to +95°F)	-10° to +60°C (+6° to +140°F)
<b>Humidity</b>	20% to 80% (non-condensing)	20% to 80% (non-condensing)

- > Leave clearance on all vented sides of the monitor to permit the required airflow
- > Never restrict airflow into the monitor by blocking any vents or air intakes
- > If the monitor is to be operated within a separate enclosure, suitable ventilation must be provided

By following these guidelines you will maximise the life of your equipment and minimise service costs.

## STATISTICS

<b>Overall Fitted Dimensions</b>	445mm (w) x 345mm (h) x 270mm (d)
<b>Weight (Mariner Kit only)</b>	Approx 2 Kg
<b>Weight (including hardware)</b>	Approx 7.75 Kg
<b>Type</b>	Active matrix, thin film transistor (TFT)
<b>Viewable Image Area</b>	20.1-inch (51cm) maximum viewable (diagonal)
<b>Screen Opening</b>	16.2 x 12.17-inch (40.8 x 30.6cm)
<b>Recommended Resolution</b>	1600 x 1200 @ 60 Hz
<b>Mariner Kit Tilt Range</b>	10 degrees down; 20 degrees up
<b>Viewing Angle (typical)</b>	Up to 178 degrees horizontal / 178 degrees vertical (10:1 minimum contrast ratio)
<b>Brightness (typical)</b>	Up to 300 nits (cd/m <sup>2</sup> )
<b>Contrast Ratio (typical)</b>	Up to 800:1
<b>Response Rate (typical)</b>	16ms (rise + fall)
<b>Pixel Pitch</b>	0.255 mm
<b>Colour Depth Support</b>	16.7 million colours
<b>Plug and Play</b>	Yes
<b>Input Signal</b>	Two DVI-I connectors (dual VGA analog or dual digital input possible)
<b>Video Cable Length</b>	6.5-ft (1.9m); detached
<b>Buttons or Switches</b>	Power on/off; 4-button OSD
<b>Power Supply</b>	90 - 265 VAC; auto-ranging, internal power supply, 50/60 Hz
<b>Power Cable Length</b>	5.9-ft (1.8m); detached

Design and specifications are subject to change without notice. E&OE.