

WALL MOUNTING DETAIL

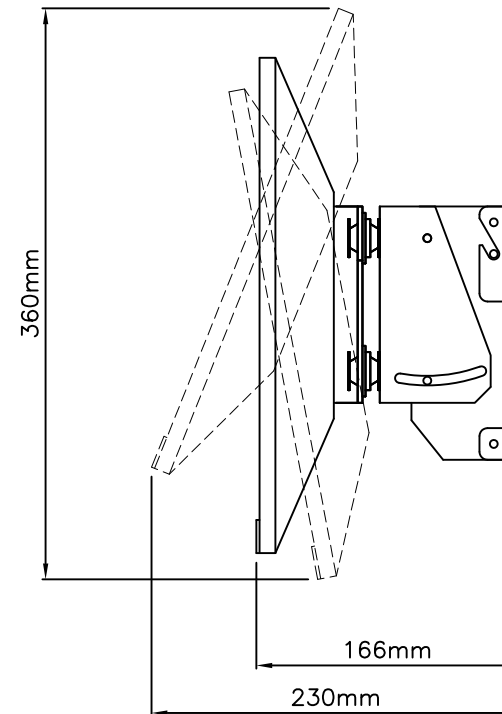

NOTES: 1) WALL MOUNTING OPTIONS (CUSTOMER PROVIDED):

- a) M5 TAPPED HOLES IN BULKHEAD
- b) M5 STUDS IN BULKHEAD

2) ALLOW 10mm CLEARANCE ON OVERALL DIMENSIONS FOR VIBRATION & VENTILATION

3) ANTI-VIBRATION MOUNT DETAIL: STOP-CHOC M2K22-00181 (4 OFF)

4) MONITOR TILT RANGE -10 / +20 DEGREES

MARINER
SYSTEMS
(UK) LTD

USED IN CONJUNCTION WITH:

HP E23 G4 FHD 23" Monitor
(WALL MOUNT)

DRAWING TITLE: MS1615 ASSEMBLY

SCALE: DRAWN 1:1
ISSUE: 1

DWG NO: MS1615_A
DATE: 18 FEB 2021