

WALL MOUNTING DETAIL

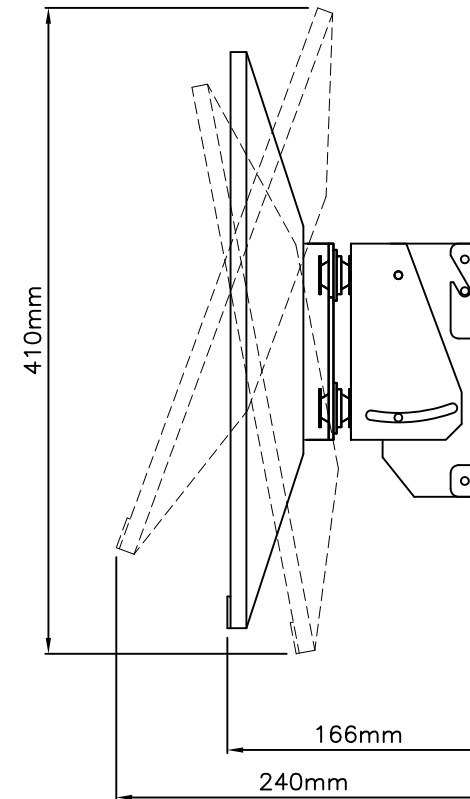

NOTES: 1) WALL MOUNTING OPTIONS (CUSTOMER PROVIDED):

- a) M5 TAPPED HOLES IN BULKHEAD
  - b) M5 STUDS IN BULKHEAD
- 2) ALLOW 10mm CLEARANCE ON OVERALL DIMENSIONS FOR VIBRATION & VENTILATION
- 3) ANTI-VIBRATION MOUNT DETAIL: STOP-CHOC M2K22-00181 (4 OFF)
- 4) ENSURE RF 1004-MST-C IN-LINE FILTER IS FITTED TO THE AC POWER SUPPLY

MARINER  
SYSTEMS  
(UK) LTD

USED IN CONJUNCTION WITH:  
HP E27 G4 FHD 27" Monitor  
(WALL MOUNT)

DRAWING TITLE: MS1655 ASSEMBLY

SCALE: DRAWN 1:1  
ISSUE: 2

DWG NO: MS1655\_A  
DATE: 15 MAR 2021