

DRILLING DETAIL

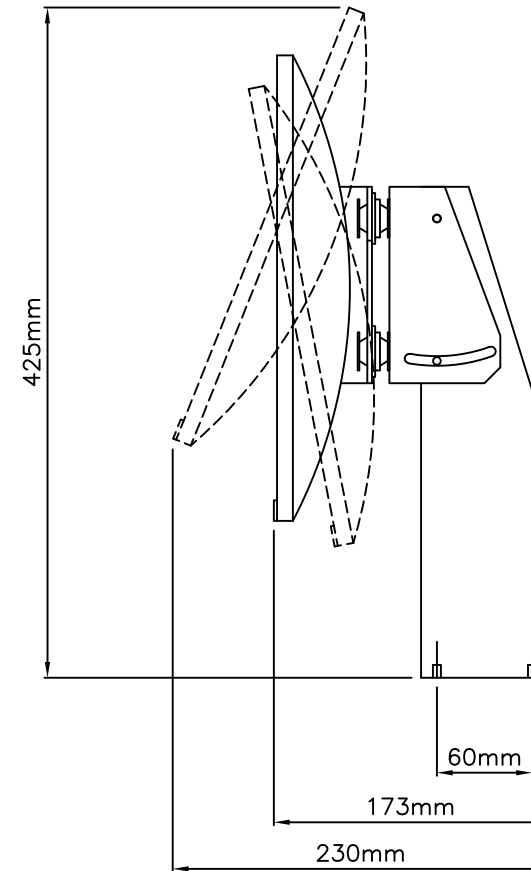

- NOTES:
- 1) SECURE BRACKET TO WORKTOP USING M5 x 20mm PAN (4 OFF) – WORKTOP ASSUMED TO BE 10mm DEPTH
 - 2) HOLE DETAILS:
'A': M5 CLEARANCE (4 OFF)
 - 3) ALLOW 10mm CLEARANCE ON OVERALL DIMENSIONS FOR VIBRATION & VENTILATION
 - 4) ANTI-VIBRATION MOUNT DETAIL: STOP-CHOC M2K22-00181 (4 OFF)
 - 5) MONITOR TILT RANGE -10 / +20 DEGREES

MARINER
SYSTEMS
(UK) LTD

USED IN CONJUNCTION WITH:
HP E22 G5 FHD 21.5" Monitor
(DESK MOUNT)

DRAWING TITLE: MS1710 ASSEMBLY

SCALE: DRAWN 1:1
ISSUE: 1

DWG NO: MS1710_A
DATE: 26 SEP 2023